

TIMING BELT

REMOVAL AND INSTALLATION

Pre-removal Operation

- Under Cover Removal
(Refer to GROUP 42 – Under Cover.)
- Engine Mount Bracket Removal
(Refer to GROUP 32 – Engine Mounting.)

Post-installation Operation

- Under Cover Installation
(Refer to GROUP 42 – Under Cover.)
- Engine Adjustment
- Engine Mount Bracket Installation
(Refer to GROUP 32 – Engine Mounting.)

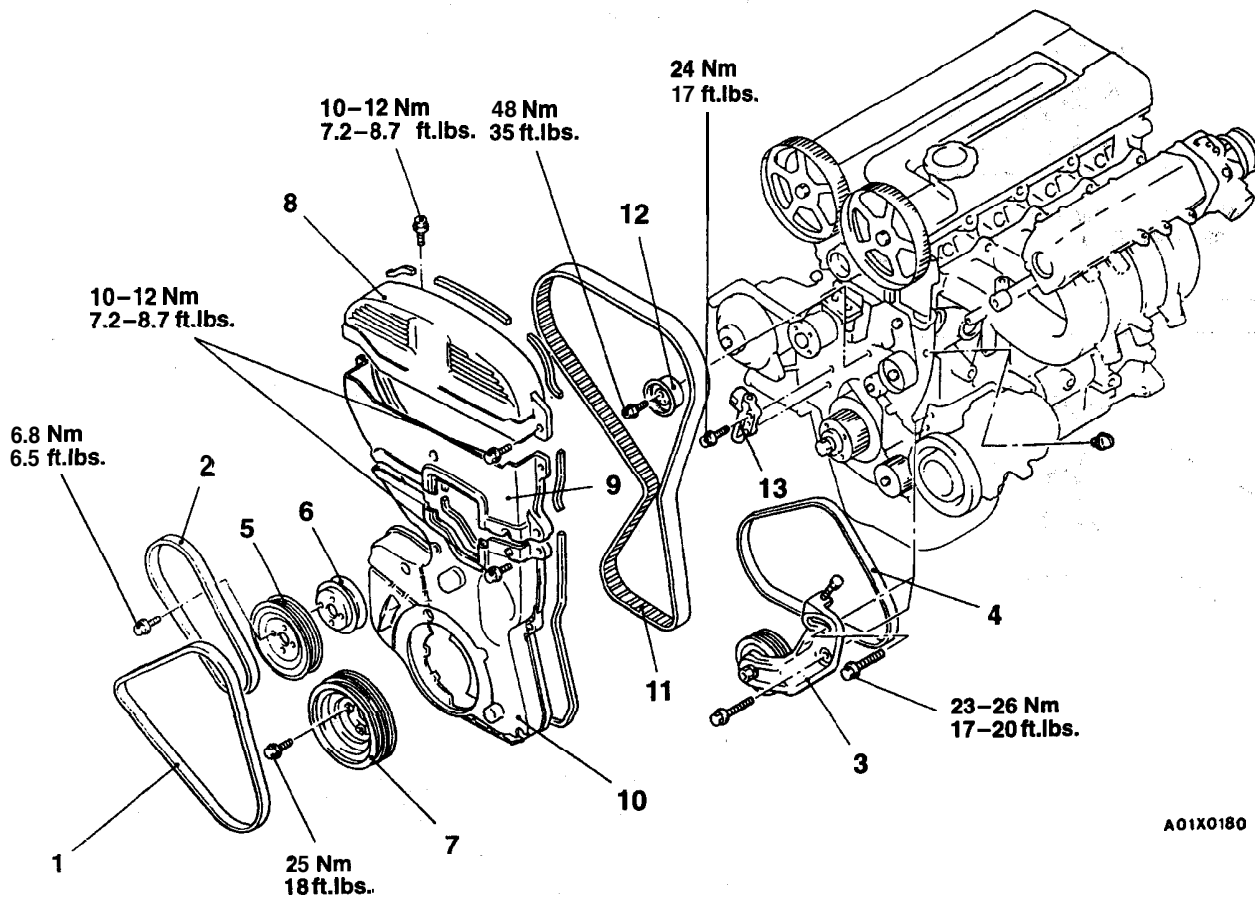

A01X0180

Removal steps

- Drive Belt Tension Adjustment
- 1. Drive belt (Generator)
- 2. Drive belt (Power steering)
- 3. Tensioner pulley bracket
- 4. Drive belt (A/C)
- 5. Water pump pulley
- 6. Water pump pulley (Power steering)

- 7. Crankshaft pulley
- ▶D◀ 8. Timing belt front upper cover
- ◀A▶▶D◀ 9. Timing belt front center cover
- ▶D◀ 10. Timing belt front lower cover
- ▶C◀ • Timing belt tension adjustment
- ◀B▶▶B◀ 11. Timing belt
- ▶A◀ 12. Tension pulley
- ▶A◀ 13. Auto tensioner

TSB Revision

REMOVAL SERVICE POINTS

◀A▶ TIMING BELT FRONT CENTER COVER

Remove the stud bolt of the engine support bracket, and remove the timing belt front center cover.

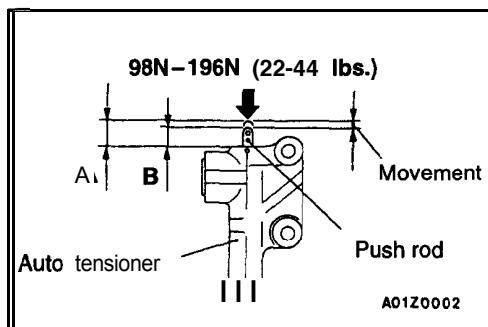
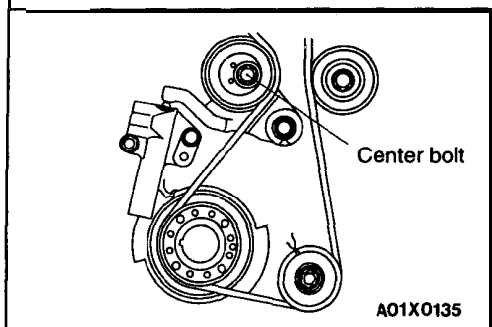
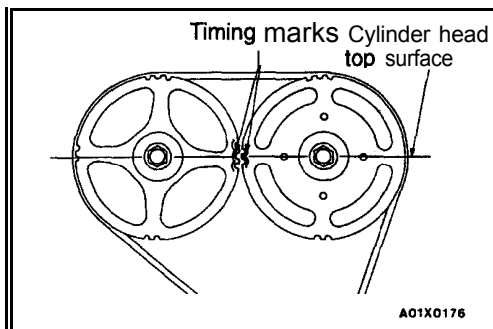

◀B▶ TIMING BELT REMOVAL

- (1) Turn the crankshaft in the forward direction (to the right) to align the camshaft sprocket timing marks.

Caution

Always turn the crankshaft in the forward direction only.

- (2) Loosen the tension pulley center bolt.
- (3) Move the tension pulley to the water pump side, and then remove the timing belt.

Caution

If the timing belt is to be reused, use chalk to mark (on its flat side) an arrow indicating the **clock-wise** direction.

INSTALLATION SERVICE POINTS

▶A◀ AUTO TENSIONER INSTALLATION

- (1) Apply 98-196 N (22-44 lbs.) force to the auto tensioner by pressing it against a metal (cylinder block,..etc.), and measure the movement of the push rod.

Standard value:

Within 1 mm (.04 in.)

A: Length when it is free (not pressed)

B: Length when it is pressed

A-B: Movement

- (2) If it is out of the standard value, replace the auto tensioner.

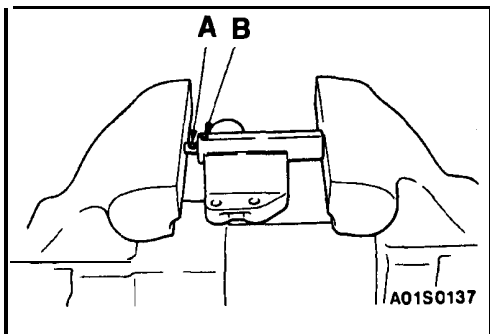

- Use a press or vise to gently compress the auto tensioner push rod until pin hole A of the push rod and pin hole B of the tensioner cylinder are aligned.

Caution

If the compression speed is too fast, the rod may become damaged, so be sure to carry out this operation slowly.

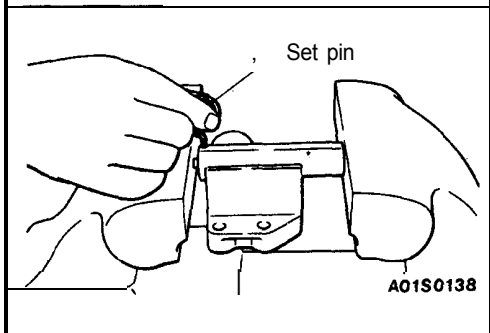

- Once the holes are aligned, insert the set pin.

NOTE

When replacing the auto tensioner with a new part, the pin will be in the auto tensioner.

- Install the auto tensioner to the engine.

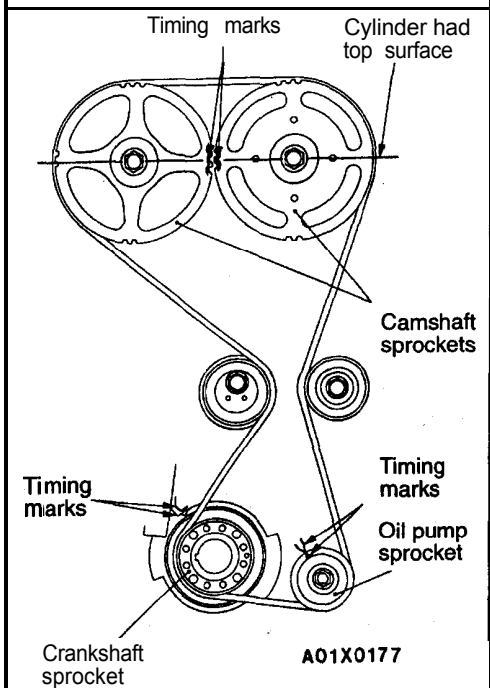

►B◄ TIMING BELT INSTALLATION'

- Align the timing marks on the camshaft sprocket, crankshaft sprocket and oil pump sprocket.

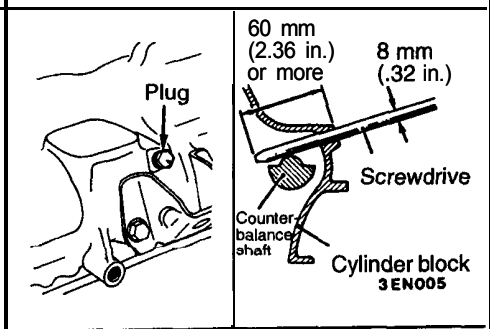

- After aligning the timing mark on the oil pump sprocket, remove the cylinder block plug and insert a Phillips screwdriver with a diameter of 8 mm (.32 in.), and check to be sure that the screwdriver goes in 60 mm (2.36 in.) or more. If the screwdriver will only go in 20 – 25 mm (.79 – .98 in.) before striking the counterbalance shaft, turn the sprocket once, realign the timing mark and check that the screwdriver goes in 60 mm (2.36 in.) or more. Do not take out the screwdriver until the timing belt is installed.

- (3) Install the timing belt so as not to be loosened among the sprockets, by the following procedure.

Cautidn

If the timing belt is to be reused, install it so that the mark indicates the clockwise direction.

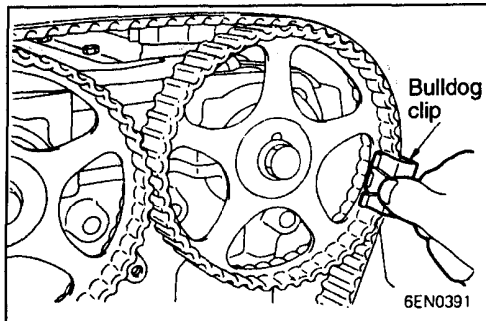

- 1) Install the timing belt around the intake side camshaft sprocket and fix it at indicated position by a bulldog clip.

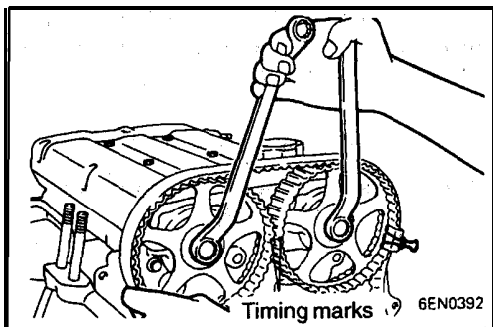

- 2) Install the timing belt around the exhaust side sprocket, aligning the timing marks with the cylinder head top surface using two wrenches.

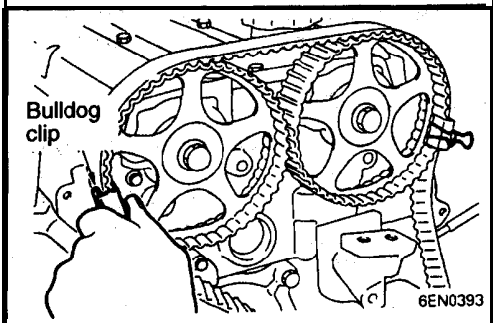

- 3) Fix the belt at indicated position by another 'bulldog clip.'
- 4) Install the timing belt around the idler pulley, the oil pump sprocket, the crankshaft sprocket and the tensioner pulleys in the order shown.
- 5) Remove the two bulldog clips.
- (4) Set the tension pulley so that the pin holes are at the bottom, press the tension pulley lightly against the timing belt.

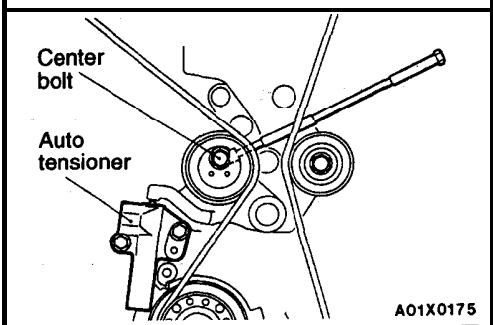

- (5) Screw the tool into the engine left support bracket until its end makes contact with the tensioner arm. At that point, screw the tool in some more and then remove the set wire attached to the auto tensioner:
- (6) Remove the tool.
- (7) Tighten the center bolt to the specified torque.

Specified torque: 48 Nm (35 ft.lbs.)

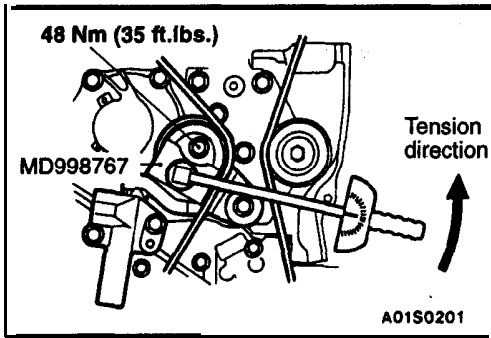

►C◄ TIMING BELT TENSION ADJUSTMENT

- (1) After turning the crankshaft 1/4 of a revolution in the counterclockwise direction, turn it in the clockwise direction until the timing marks are aligned.
- (2) Loosen the tension pulley fixing bolt, and then use the special tool and a torque wrench to tighten the fixing bolt to the specified torque while applying tension to the timing belt.

Standard value:
 3.5 Nm (2.6 ft.lbs.)
 <Timing belt tension torque>

Caution
 When tightening the fixing bolt, 'do not let the tension pulley turn with the bolt.'

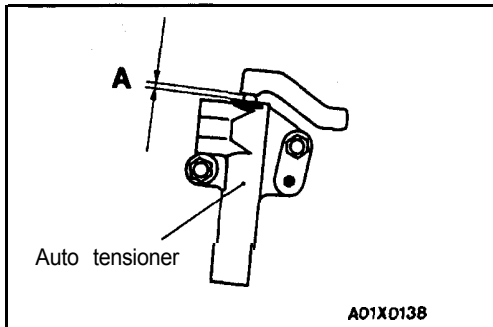

- (3) Turn the crankshaft two revolutions clockwise so that the timing marks are aligned. After leaving it for 15 minutes, measure the amount of protrusion of the auto tensioner.

Standard value (A): 3.8-4.5 mm (.150-.177 in.)

- (4) If the amount of protrusion is outside the standard value, repeat the operation in steps (1) to (3).
- (5) Check again that the timing marks of each sprocket are aligned.

►D◄ TIMING BELT FRONT LOWER.. COVER/ TIMING BELT FRONT CENTER COVER/ TIMING BELT FRONT UPPER COVER INSTALLATION

Install the bolts, being careful not to mistake the bolt sizes.

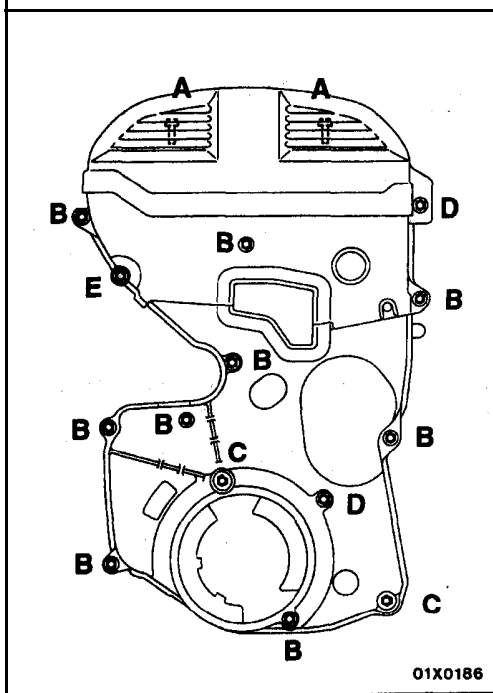

	Thread diameter × thread length mm (in.)	Bolt classification	Tightening torque Nm (ft.lbs.)
A	6 × 16 (.24 × .63)	Flange bolt	10-12 (7.2-8.7)
B	6 × 18 (.24 × .71)	Flange bolt	10-12 (7.2-8.7)
C	6 × 25 (.24 × .98)	Washer assembled bolt	8.8 (6.5)
D	6 × 25 (.24 × .98)	Flange bolt	10-12 (7.2-8.7)
E	6 × 45 (.24 × 1.77)	Flange bolt	10-12 (7.2-8.7)

TIMING BELT B

REMOVAL AND INSTALLATION

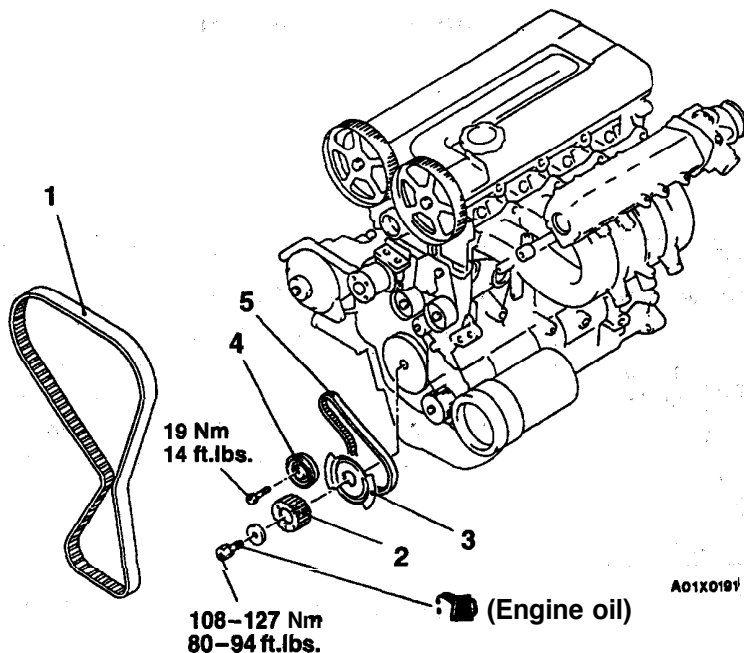

Removal steps

- 1. Timing belt (Refer to P.11A-36.)
- ◀A▶▶D▶ 2. Crankshaft sprocket
- ▶C▶ 3. Crankshaft sensing blade
- ▶B▶ • Timing belt B tension adjustment
- 4. Timing belt B tensioner
- ▶B▶▶A▶ 5. Timing belt B

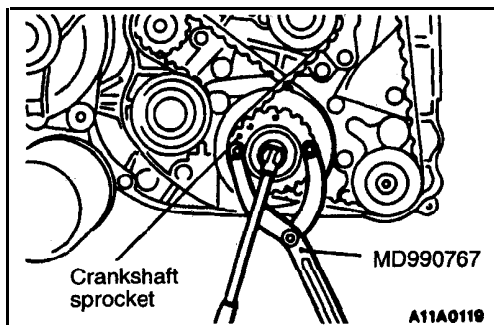

REMOVAL SERVICE POINTS

◀A▶ **CRANKSHAFT SPROCKET REMOVAL**

(1) Use the special tool to remove the bolt,

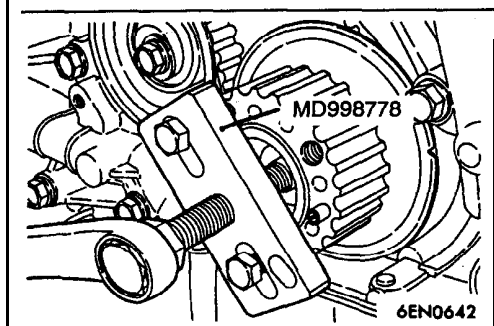

(2) Use the special tool to remove the crankshaft sprocket.

◀B▶ TIMING BELT B REMOVAL

Caution

If timing belt "B" is to be re-used, use chalk to mark it with an arrow on its flat side indicating the turning direction (to the right).

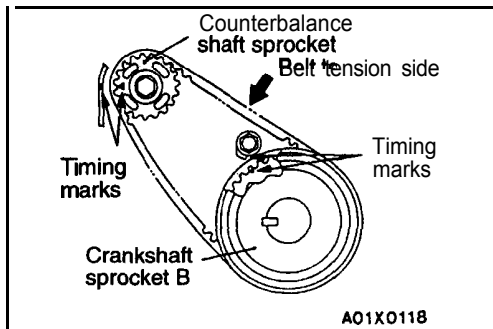

INSTALLATION SERVICE POINTS

▶A◀ TIMING BELT B INSTALLATION

Install timing belt "B" by the following procedure.

- (1) Ensure that crankshaft sprocket "B" timing mark and the counterbalance shaft sprocket timing mark are aligned.
- (2) Fit timing belt "B" over crankshaft sprocket "B" and the silent shaft sprocket. Ensure that there is no slack in the belt.

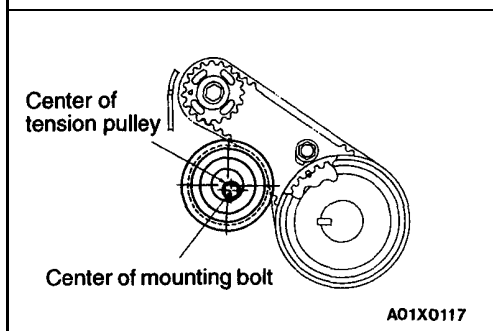

▶B◀ TIMING BELT B TENSION ADJUSTMENT

Adjust the tension of timing belt "B" by the following procedure.

- (1) Temporarily fix the timing belt "B" tensioner such that the center of the tensioner pulley is to the left and above the center of the installation bolt, and temporarily attach the tensioner pulley so that the flange is toward the front of the engine.

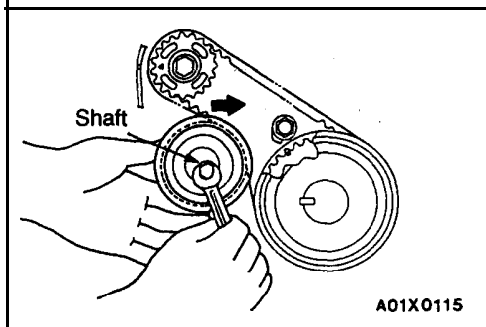

- (2) Holding the timing belt "B" tensioner up with your finger in the direction of the arrow, place pressure on the timing belt so that the tension side of the belt is taut. Now tighten the bolt to fix the tensioner.

Caution

When tightening the bolt, ensure that the tensioner pulley shaft does not rotate with the bolt. Allowing it to rotate with the bolt can cause excessive tension on the belt.

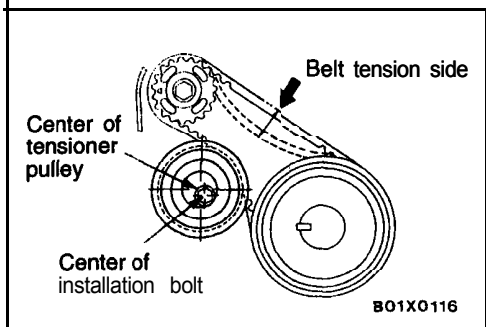

- (3) Press the belt at the shown point by a finger to check belt tension. If not, adjust.

Standard value: 5-7 mm (.20-.28 In.)

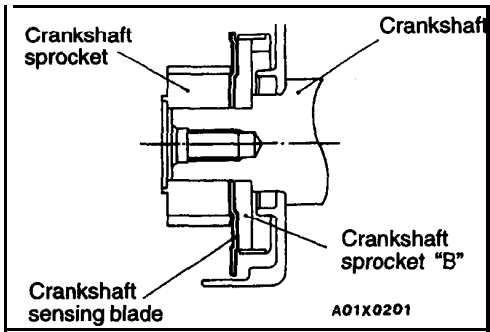

▶◀ **CRANKSHAFT SENSING BLADE INSTALLATION**

When installing, make sure the direction is correct. See figure.

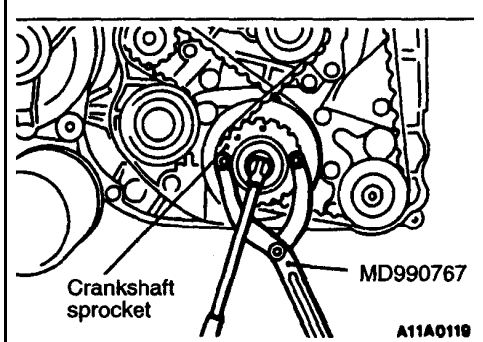

▶◀ **CRANKSHAFT SPROCKET INSTALLATION**

Use the special tool to install the crankshaft sprocket and bolt.

NOTE

Apply the minimum amount of engine oil to the bearing surface and thread of the crankshaft bolt.